

NO.	DATE	REVISION

NO.	DATE	REVISION	DESIGN	CHK

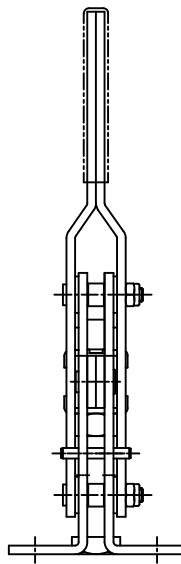
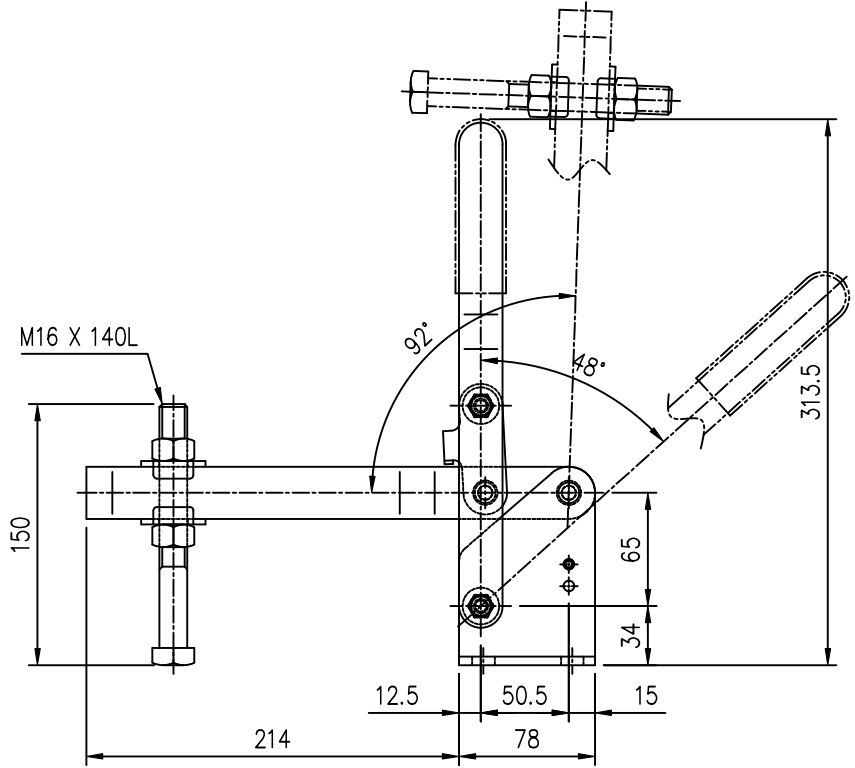
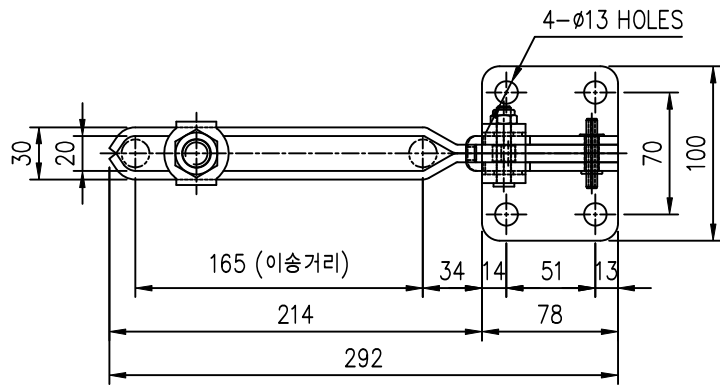

GENERAL TOLERANCE		DIMENSIONAL TOLERANCE		SURFACE TOLERANCE		MATERIAL		REMARKS	
NO.	UNIT	MIN.	MAX.	MIN.	MAX.	MIN.	MAX.	NO.	REMARKS
1-3	mm	±0.10	±0.15	±0.10	±0.15				
4-10	mm	±0.15	±0.20	±0.15	±0.20				
11-20	mm	±0.20	±0.25	±0.20	±0.25				
21-50	mm	±0.30	±0.35	±0.30	±0.35				
51-100	mm	±0.40	±0.45	±0.40	±0.45				
101-200	mm	±0.50	±0.55	±0.50	±0.55				