

적용 도면 (Applied DRAW. No.)		MARK		DATE	DETAIL OF REVISION		CHECK	APP.
도면 번호 (DRAW. No.)	비고 (Remarks)	△						
1		△						
2								

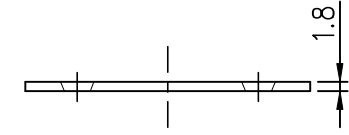
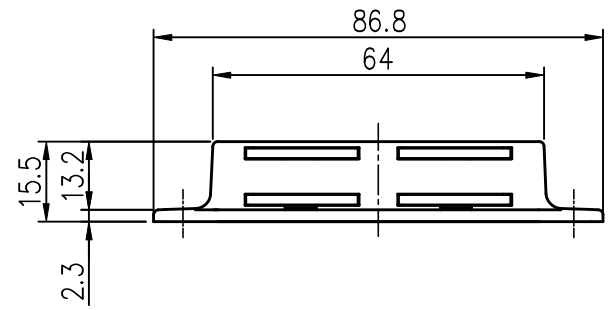
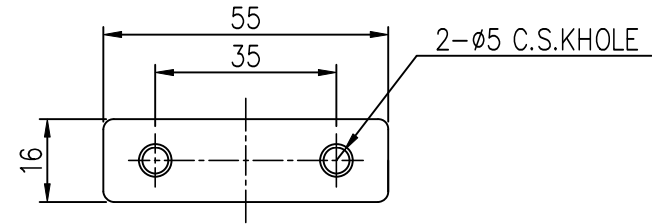
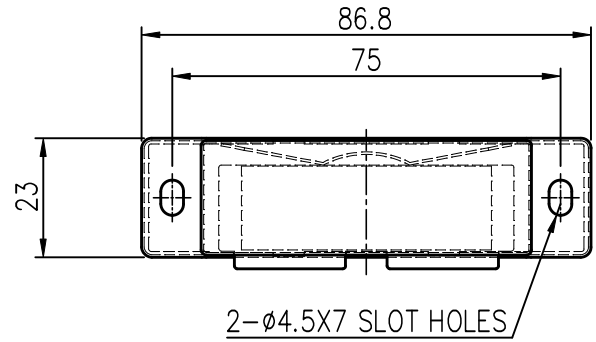

주 기

1. 샘플 승인 득한후 양산할 것.
2. 지시하지 않은 모퉁기와 모따기는 자연 R과 C로 할 것.
3. 본 제품의 가공 공차는 일반공차 B등급을 적용한다.
4. 기타 자세한 사항은 설계자와 협의한다.

DIVISION	GRADE	A LEVEL	B LEVEL	C LEVEL
1-4	±0.05	±0.10	±0.25	
4-6	±0.07	±0.20	±0.35	
16-63	±0.10	±0.30	±0.50	
63-250	±0.18	±0.55	±0.90	
250-500	±0.30	±0.90	±1.50	
500-1000	±0.50	±1.50	±2.50	

부 품 번 Part No.		번호 No.	명 칭 Part Name		갯수 Qt'y	재 질 Material	비 고 Remarks
DRAWN	CHECKED	CHECKED	APPROVED	SCALE : 1/1	MODEL :		
				UNIT : MM	TITLE :		
				SIZE : A3	THIRD ANGLE PROJECTION	MODEL No.	
				DATE :		DWG No.	